

# 7.5-20 Watt Hybrid

## Features

- Specifically designed for aircraft applications
- Completely self contained Thick Film Hybrid DC-DC Converter
- No external filter caps required
- Fully isolated design
- "Inhibit-not" function
- Power on soft start
- 200 kHz operation for low ripple and fast response time
- Built-in EMI input filter meets MIL-STD-461C requirements CE01, CE03, CS01, CS02 and CS06
- Short circuit and overvoltage protection
- Capability of external sync for switching frequencies
- Built-in test capability

## Specifications

**INPUT:** 270 VDC nominal  
 Range: 185 to 335 VDC continuous  
 Survives 440 V transients

### ISOLATION:

Input to case: 500 VDC  
 Input to output: 500 VDC  
 Output to case: 100 VDC

### ENVIRONMENT:

Storage temperature: -55°C to +150°C  
 Shock: 50 G's  
 Acceleration: 500 G's  
 Vibration: 30 G's

### Grade M:

Full Power Output at  $T_{case} = +85^{\circ}C$   
 Linearly derates to zero at  $T_{case} = +115^{\circ}C$

### Grade E:

Full Power Output at  $T_{case} = +125^{\circ}C$   
 Linearly derates to zero at  $T_{case} = +135^{\circ}C$

**WEIGHT:** 60 grams typical

SINGLE OUTPUT DEVICES		3109-S03.3 (13.2W)			3109-S05 (20W)			3108-S05.2 (20W)			3109-S12 (20W)		
PARAMETER	CONDITION	MIN	TYP	MAX	MIN	TYP	MAX	MIN	TYP	MAX	MIN	TYP	MAX
Output voltage	—	+3.2	+3.3	+3.4	+4.9	+5.0	+5.1	+5.1	+5.2	+5.3	+11.9	+12.0	+12.1
Output current	$V_{in\ min} - V_{in\ max}$	—	—	4A	—	—	4A	—	—	3.85A	—	—	1.67A
Efficiency	$P_{out} = \text{max rated load}$	65%	68%	—	70%	73%	—	70%	73%	—	77%	81%	—
Line regulation	$P_{out} = \text{max rated load}$ $V_{in\ min} - V_{in\ max}$	—	10mV	30mV	—	10mV	50mV	—	10mV	50mV	—	20mV	100mV
Load regulation	$P_{out} = 10\%$ to F.L.	—	10mV	30mV	—	10mV	50mV	—	10mV	50mV	—	20mV	100mV
Output ripple	F.L. BW 2 MHz mV <sub>pp</sub>	—	30	65	—	40	85	—	40	85	—	60	150

SINGLE OUTPUT DEVICES		3109-S15 (20W)			3109-S28 (20W)								
PARAMETER	CONDITION	MIN	TYP	MAX	MIN	TYP	MAX						
Output voltage	—	+14.9	+15.0	+15.1	+27.8	+28.0	+28.2						
Output current	$V_{in\ min} - V_{in\ max}$	—	—	1.33A	—	—	714mA						
Efficiency	$P_{out} = \text{max rated load}$	78%	82%	—	77%	81%	—						
Line regulation	$P_{out} = \text{max rated load}$ $V_{in\ min} - V_{in\ max}$	—	25mV	125mV	—	50mV	250mV						
Load regulation	$P_{out} = 10\%$ to F.L.	—	25mV	125mV	—	50mV	250mV						
Output ripple	F.L. BW 2 MHz mV <sub>pp</sub>	—	75	180	—	150	350						

Model No.	Case Style	Pin Count	Mounting
3109	2	12	Solder Sealed Flangeless PCB Mount
3109 F	3	12	Solder Sealed PCB Mount with Flange
3109 H	5	12	Seam Weld Flangeless PCB Mount
3109 HF	6	12	Seam Weld PCB Mount with Flange
3109 VF	8	12	Seam Weld Chassis Mount with Flange

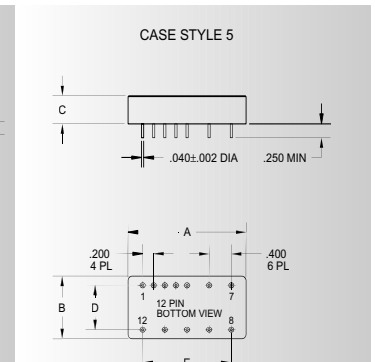
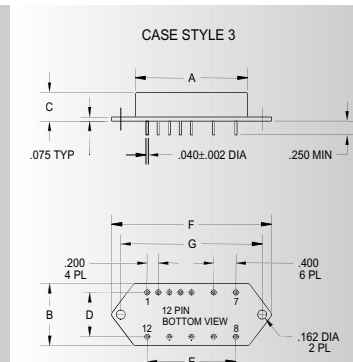
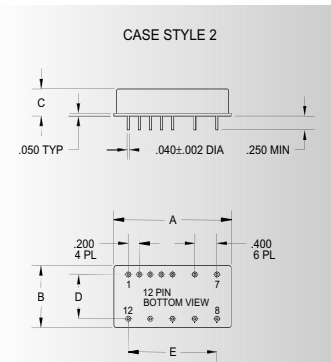

TOLERANCES: ALL DIMENSIONS ±0.01 EXCEPT F = MAX, C = +0.01/-0.02; DRAWINGS IN INCHES.

## Case Dimensions

Units: inches | millimeters

Case Style	A	B	C	D	E	F	G
2	2.130   54.102	1.120   28.448	0.495   12.573	0.800   20.320	1.600   40.640	—   —	—   —
3 F	2.130   54.102	1.120   28.448	0.495   12.573	0.800   20.320	1.600   40.640	2.890   73.406	2.550   64.770
5 H	2.130   54.102	1.120   28.448	0.495   12.573	0.800   20.320	1.600   40.640	—   —	—   —
6 HF	2.130   54.102	1.120   28.448	0.495   12.573	0.800   20.320	1.600   40.640	2.890   73.406	2.550   64.770
8 VF	2.160   54.864	1.510   38.354	0.495   12.573	—   —	1.600   40.640	2.890   73.406	2.550   64.770

# DC-DC CONVERTERS

# FULL FEATURE SERIES 3109

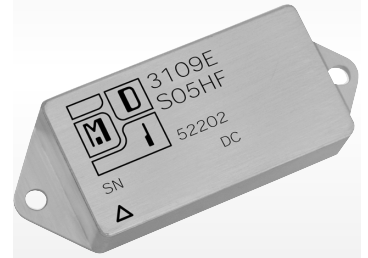

## 270 VDC

0006

DUAL OUTPUT DEVICES		3109-D3.3/5 (11.6W)			3109-D05 (20W)			3109-D12 (20W)			3109-D15 (20W)		
PARAMETER	CONDITION	MIN	TYP	MAX	MIN	TYP	MAX	MIN	TYP	MAX	MIN	TYP	MAX
Output voltage	$+I_{out} = -I_{out}$	+3.2	+3.3	+3.4	+4.9	+5.0	+5.1	+11.9	+12.0	+12.1	+14.9	+15.0	+15.1
		+4.9	+5.0	+5.1	-4.9	-5.0	-5.1	-11.9	-12.0	-12.1	-14.9	-15.0	-15.1
Output current*	$V_{in\ min} - V_{in\ max}$	200mA	—	2A	±150mA	—	±2A	±125mA	—	±833mA	±100mA	—	±667mA
		100mA	—	1A	—	—	—	—	—	—	—	—	—
Efficiency	$P_{out} = \text{max rated load}$	62%	65%	—	72%	75%	—	77%	81%	—	78%	82%	—
Line regulation	$P_{out} = \text{max rated load}$ $V_{in\ min} - V_{in\ max}$	—	10mV	30mV	—	±10mV	±50mV	—	±20mV	±100mV	—	±25mV	±125mV
		—	10mV	50mV	—	±10mV	±50mV	—	±20mV	±100mV	—	±25mV	±125mV
Load regulation†	$P_{out} = 10\%$ to F.L.	—	10mV	30mV	—	±10mV	±50mV	—	±20mV	±100mV	—	±25mV	±125mV
		—	10mV	50mV	—	±10mV	±50mV	—	±20mV	±100mV	—	±25mV	±125mV
Output ripple	F.L. BW 2 MHz mV <sub>pp</sub>	—	30	65	—	40	85	—	60	150	—	75	180
		—	25	50	—	—	—	—	—	—	—	—	—

Notes: \*Up to 90% full power available from either output if rated output power is not exceeded; †balanced load conditions.

TRIPLE OUTPUT DEVICES		3109-T3.3/5 (7.5W)			3109-T3.3/12 (10W)			3109-T3.3/15 (10W)			3109-T05 (7.5W)			3109-T12 (10W)			3109-T15 (10W)					
PARAMETER	CONDITION	MIN	TYP	MAX	MIN	TYP	MAX	MIN	TYP	MAX	MIN	TYP	MAX	MIN	TYP	MAX	MIN	TYP	MAX			
Output voltage	$+I_{out} = -I_{out}$	+3.2	+3.3	+3.4	+3.2	+3.3	+3.4	+3.2	+3.3	+3.4	+4.9	+5.0	+5.1	+4.9	+5.0	+5.1	+11.9	+12.0	+12.1	+14.9	+15.0	+15.1
		+4.9	+5.0	+5.1	+11.9	+12.0	+12.1	+14.9	+15.0	+15.1	-4.9	-5.0	-5.1	-11.9	-12.0	-12.1	-14.9	-15.0	-15.1			
Output current	$V_{in\ min} - V_{in\ max}$	150mA	—	1.5A	150mA	—	1.5A	150mA	—	1.5A	60mA	—	1A	30mA	—	1A	30mA	—	1A	30mA	—	1A
		±15mA	—	±250mA	±15mA	—	±208mA	±15mA	—	±167mA	±15mA	—	±250mA	±15mA	—	±208mA	±15mA	—	±167mA			
Efficiency	$P_{out} = \text{max rated load}$	65%	68%	—	65%	68%	—	65%	68%	—	65%	68%	—	70%	73%	—	70%	73%	—	70%	73%	—
Line regulation	$P_{out} = \text{max rated load}$ $V_{in\ min} - V_{in\ max}$	—	10mV	50mV	—	10mV	50mV	—	10mV	50mV	—	10mV	50mV	—	10mV	50mV	—	10mV	50mV	—	10mV	50mV
		—	25mV	50mV	—	25mV	50mV	—	25mV	50mV	—	25mV	50mV	—	25mV	50mV	—	25mV	50mV	—	25mV	50mV
Load regulation	$P_{out} = 10\%$ to F.L.	—	10mV	50mV	—	10mV	50mV	—	10mV	50mV	—	10mV	50mV	—	10mV	50mV	—	10mV	50mV	—	10mV	50mV
		—	25mV	50mV	—	25mV	50mV	—	25mV	50mV	—	25mV	50mV	—	25mV	50mV	—	25mV	50mV	—	25mV	50mV
Output ripple	F.L. BW 2 MHz mV <sub>pp</sub>	—	30	65	—	30	65	—	30	65	—	40	85	—	40	85	—	40	85	—	40	85
		—	—	50	—	—	50	—	—	50	—	—	50	—	—	50	—	—	50	—	—	50

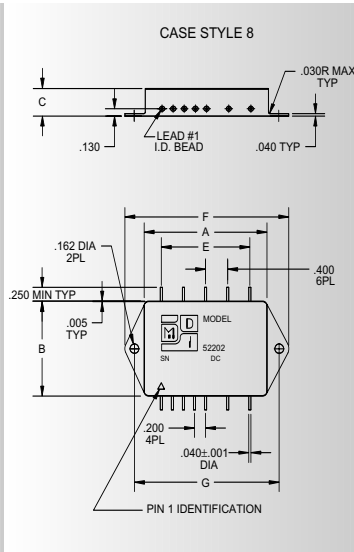
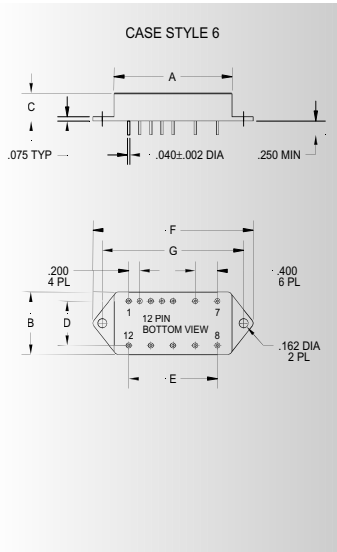

### 3109-SXX output <24 VDC

Pin 1	bit	Pin 7	+ input
Pin 2	inhibit not	Pin 8	main output
Pin 3	soft start	Pin 9	main output ret
Pin 4	sync	Pin 10	N/C
Pin 5	N/C	Pin 11	adjust
Pin 6	input ret	Pin 12	N/C

### 3109-SXX output ≥24 VDC

Pin 1	bit	Pin 7	+ input
Pin 2	inhibit not	Pin 8	N/C
Pin 3	soft start	Pin 9	N/C
Pin 4	sync	Pin 10	main output
Pin 5	N/C	Pin 11	N/C
Pin 6	input ret	Pin 12	main output ret

### 3109-DXX

Pin 1	bit	Pin 7	+ input
Pin 2	inhibit not	Pin 8	N/C
Pin 3	soft start	Pin 9	N/C
Pin 4	sync	Pin 10	+ dual output
Pin 5	N/C	Pin 11	dual output ret
Pin 6	input ret	Pin 12	- dual output

### 3109-TXX

Pin 1	bit	Pin 7	+ input
Pin 2	inhibit not	Pin 8	main output
Pin 3	soft start	Pin 9	main output ret
Pin 4	sync	Pin 10	+ dual output
Pin 5	N/C	Pin 11	dual output ret
Pin 6	input ret	Pin 12	- dual output

Please specify **GRADE LEVEL** for your application. Industrial grade units will be shipped if no option is specified.

- M** +85°C military
- E** +125°C military