

12 – 30 WATT HYBRID

DC-DC Converters

SERIES 6681

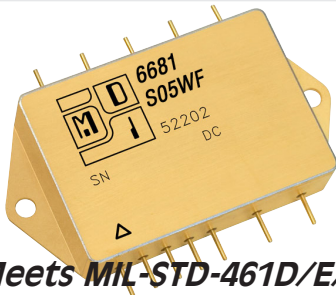

**Meets MIL-STD-461D/E/F
CE/CS Input Power Leads**

Features

- Built-In EMI filter meets MIL-STD-461D/E/F CE101, CE102, CS101, CS114, CS115 and CS116. Also meets DO-160C/D/E/F/G CE Section 21 and CS Sections 20, 22
- 28 VDC input for MIL-STD-704A applications
- Completely self contained Thick Film Hybrid DC-DC Converter
- No external filter elements required
- "Inhibit-not" function
- Short circuit protection
- Fully isolated, input to output
- Single or dual outputs
- 250 kHz operation for low ripple and fast response time
- Full hermetic package
- External sync for switching frequencies
- Built-in test capability

Specifications

INPUT: 28 VDC nominal
Range: 16 to 50 VDC continuous
 18 to 50 VDC full power
 Operates through 80 V transients/MIL-STD-704A

ISOLATION:
 Input to case: 500 VDC
 Input to output: 500 VDC

ENVIRONMENT:
 Storage temperature: -55°C to +150°C
 Shock: 50 G's
 Acceleration: 500 G's
 Vibration: 30 G's
 Grades M:
 Full Output Power at $T_{case} = +85^{\circ}C$
 Linearly derates to zero at $T_{case} = +115^{\circ}C$

Grades E:
 Full Power Output at $T_{case} = +125^{\circ}C$
 Linearly derates to zero at $T_{case} = +135^{\circ}C$

WEIGHT: 75 grams typical

SINGLE OUTPUT CONVERTERS		6681-S02 (12W)			6681-S02.5 (15W)			6681-S03.3 (20W)			6681-S05 (30W)		
PARAMETER	CONDITION	MIN	TYP	MAX	MIN	TYP	MAX	MIN	TYP	MAX	MIN	TYP	MAX
Output voltage	—	+1.9	+2.0	+2.1	+2.4	+2.5	+2.6	+3.2	+3.3	+3.04	+4.9	+5.0	+5.1
Output current	$V_{in} \text{ min} - V_{in} \text{ max}$	—	—	6.06A	—	—	6.06A	—	—	6.06A	—	—	6A
Efficiency	$P_{out} = \text{max rated load}$	56%	59%	—	61%	64%	—	66%	69%	—	71%	74%	—
Line regulation	$V_{in} \text{ min} - V_{in} \text{ max}$ $P_{out} = \text{max rated load}$	—	10mV	30mV	—	10mV	30mV	—	10mV	30mV	—	10mV	50mV
Load regulation	$V_{in} \text{ min} - V_{in} \text{ max}$ $P_{out} = 10\% \text{ to F.L.}$	—	10mV	30mV	—	10mV	30mV	—	10mV	30mV	—	10mV	50mV
Output ripple	F.L. BW 2 MHz mV _{pp}	—	25	50	—	30	60	—	30	65	—	40	85

SINGLE OUTPUT CONVERTERS		6681-S05.2 (30W)			6681-S12 (30W)			6681-S15 (30W)			6681-S28 (30W)		
PARAMETER	CONDITION	MIN	TYP	MAX	MIN	TYP	MAX	MIN	TYP	MAX	MIN	TYP	MAX
Output voltage	—	+5.1	+5.2	+5.3	+11.9	+12.0	+12.1	+14.9	+15.0	+15.1	+27.8	+28.0	+28.2
Output current	$V_{in} \text{ min} - V_{in} \text{ max}$	—	—	5.76A	—	—	2.5A	—	—	2A	—	—	1.07A
Efficiency	$P_{out} = \text{max rated load}$	71%	74%	—	78%	82%	—	79%	83%	—	78%	82%	—
Line regulation	$V_{in} \text{ min} - V_{in} \text{ max}$ $P_{out} = \text{max rated load}$	—	10mV	50mV	—	20mV	100mV	—	25mV	125mV	—	50mV	250mV
Load regulation	$V_{in} \text{ min} - V_{in} \text{ max}$ $P_{out} = 10\% \text{ to F.L.}$	—	10mV	50mV	—	20mV	100mV	—	25mV	125mV	—	50mV	250mV
Output ripple	F.L. BW 2 MHz mV _{pp}	—	40	85	—	60	150	—	75	180	—	150	350

DUAL OUTPUT DEVICES		6681-D3.3/5 (15W)			6681-D05 (30W)			3650-D12 (30W)			6681-D15 (30W)		
PARAMETER	CONDITION	MIN	TYP	MAX	MIN	TYP	MAX	MIN	TYP	MAX	MIN	TYP	MAX
Output voltage	+I = -I	+3.2	+3.3	+3.4	+4.9	+5.0	+5.1	+11.9	+12.0	+12.1	+14.9	+15.0	+15.1
Output current*	$V_{in} \text{ min} - V_{in} \text{ max}$	300mA	—	3A	±150mA	—	±3A	±95mA	—	±1.25A	±76mA	—	±1A
Efficiency	$P_{out} = \text{max rated load}$	63%	66%	—	72%	76%	—	78%	82%	—	79%	83%	—
Line regulation	$V_{in} \text{ min} - V_{in} \text{ max}$ $P_{out} = \text{max rated load}$	—	±10mV	±50mV	—	±10mV	±50mV	—	±20mV	±100mV	—	±25mV	±125mV
Load regulation†	$P_{out} = 10\% \text{ to F.L.}$	—	±10mV	±50mV	—	±10mV	±50mV	—	±20mV	±100mV	—	±20mV	±100mV
Output ripple	F.L. BW 2 MHz mV _{pp}	—	30	65	—	40	85	—	60	150	—	75	180

Notes: *Up to 90% full power available from either output if rated output power is not exceeded; †balanced load conditions.

Model No.	Case Style	Pin Count	Mounting
6681	2	12	Solder Sealed Flangeless PCB Mount
6681	F	12	Solder Sealed PCB Mount with Flange
6681	I	12	Seam Weld Flangeless PCB Mount
6681	IF	12	Seam Weld PCB Mount with Flange
6681	WF	12	Seam Weld Chassis Mount with Flange
6681	PB	10	Solder Sealed Flangeless PCB Stud Mount
6681	PE	12	Seam Weld PCB Stud Mount

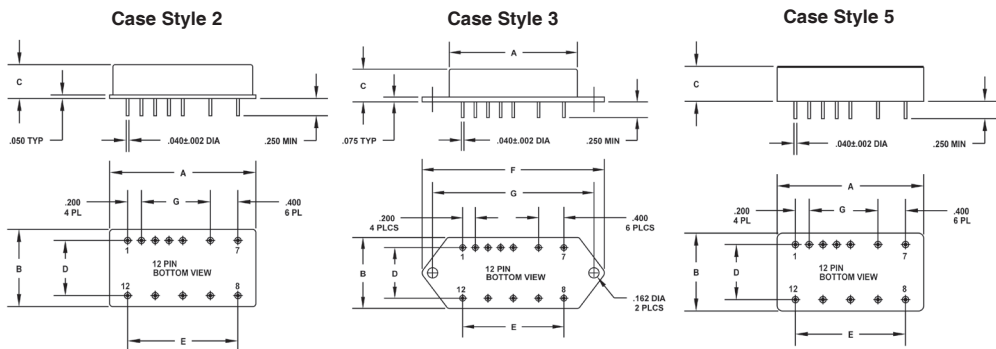

Case Dimensions

Units: inches | millimeters

TOLERANCES: Drawings in Inches All dimensions ±0.01 except F = max, C = +0.01/-0.020 For Custom Packages, Contact Factory

Case Style	A	B	C	D	E	F	G
2	2.200 55.880	1.350 34.290	0.495 12.573	1.000 25.400	1.600 40.640	— —	— —
3	2.200 55.880	1.350 34.290	0.495 12.573	1.000 25.400	1.600 40.640	2.960 75.184	2.610 66.294
5	2.225 56.515	1.350 34.290	0.495 12.573	1.000 25.400	1.600 40.640	— —	— —
6	2.225 56.515	1.350 34.290	0.495 12.573	1.000 25.400	1.600 40.640	2.960 75.184	2.610 66.294
8	2.225 56.515	1.710 43.434	0.495 12.573	— —	1.600 40.640	2.960 75.184	2.610 66.294
10	2.225 56.515	1.350 34.290	0.495 12.573	1.000 25.400	1.600 40.640	— —	— —
12	2.225 56.515	1.350 34.290	0.495 12.573	1.000 25.400	1.600 40.640	— —	— —



Modular Devices, Inc • One Roned Road • Shirley, New York 11967 • E-mail sales@mdipower.com • Fax 631.345.3106 • Tel 631.345.3100

MIL-STD-461D/E/F AND DO-160 APPLICATIONS

The 6681 series comprise state-of-the-art DC-DC converters that fulfill the latest Electromagnetic Interference Compatibility (EMC) requirements for Aerospace, Defense and Civil Aviation airborne electronics applications.

Very compact and highly efficient, each 6681 model incorporates a completely self-contained input EMI filter that enables compliance with:

- MIL-STD-461D/E/F:
 - Conducted Emissions (CE)
 - CE101, power leads, 30Hz - 10kHz
 - CE102, power leads, 10kHz - 10MHz
 - Conducted Susceptibility (CS)
 - CS101, power leads, 30Hz - 150kHz
 - CS114, bulk cable injection, 10kHz - 200MHz
 - CS115, bulk cable injection, impulse excitation
 - CS116, cables and power leads, damped sinusoid transients, 10kHz - 100MHz
- DO-160 C/D/E/F/G:
 - Conducted Emissions (CE)
 - Section 21: power lines, emissions 15kHz - 30MHz, categories B, LMH, AZ
 - Conducted Susceptibility (CS)
 - Section 20: power lines, 10kHz - 400MHz
 - Section 22: lightning induced transients

Moreover, the 6681 design is robust enough to operate through MIL-STD-704A 80V/100mS power line transients.

Available in all-hermetic standard solder-sealed or optional seam-welded packages, flanged and non-flanged.

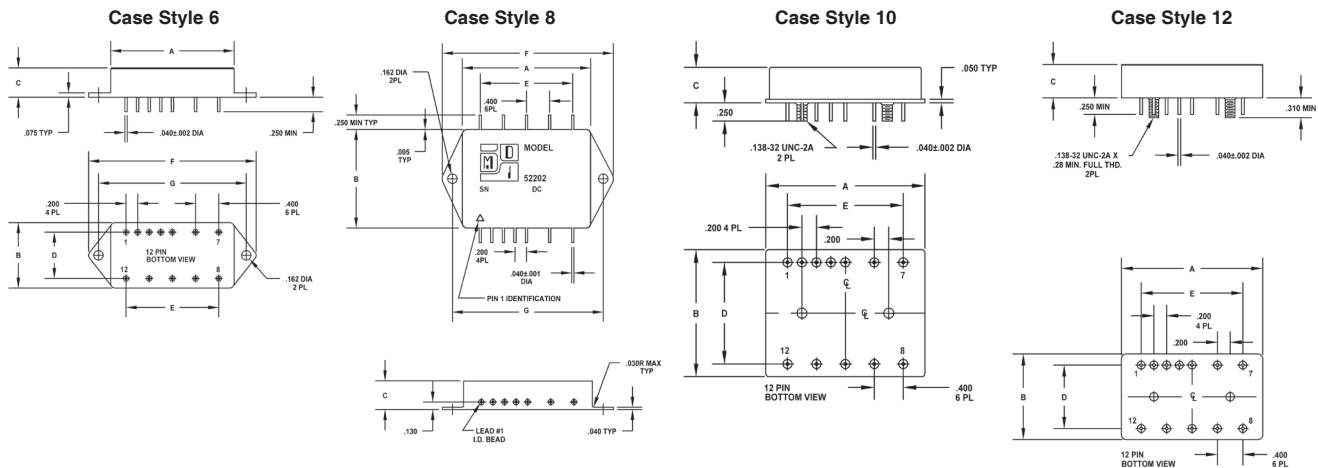
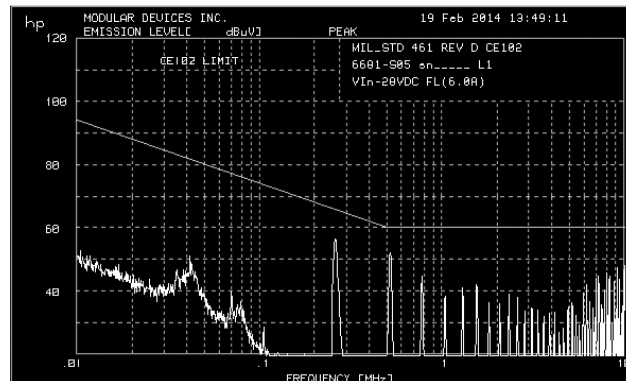

6681-SXX output <24 VDC				6681-SXX output ≥ 24 VDC				6681-DXX			
Pin 1	bit	Pin 7	+ input	Pin 1	bit	Pin 7	+ input	Pin 1	bit	Pin 7	+ input
Pin 2	Inhibit not	Pin 8	main output	Pin 2	Inhibit not	Pin 8	N/C	Pin 2	Inhibit not	Pin 8	N/C
Pin 3	soft start	Pin 9	main output ret	Pin 3	soft start	Pin 9	N/C	Pin 3	soft start	Pin 9	N/C
Pin 4	sync	Pin 10	+ remote sense	Pin 4	sync	Pin 10	main output	Pin 4	sync	Pin 10	+ dual output
Pin 5	N/C	Pin 11	adjust	Pin 5	N/C	Pin 11	N/C	Pin 5	N/C	Pin 11	dual output rtn
Pin 6	input ret	Pin 12	- remote sense	Pin 6	input ret	Pin 12	main output ret	Pin 6	input ret	Pin 12	- dual output

GRADE LEVELS:

Please specify **GRADE LEVEL** for your application. **Industrial grade** units will be shipped if no option is specified.

Industrial Grade	-55°C to +85°C Test data 25°C with 24 hours 25°C burn-in
M Grade	-55°C to +85°C Test data -55°C, +25°C, +85°C with 160 hours 85°C burn-in
E Grade	-55°C to +125°C Test data -55°C, +25°C, +125°C with 160 hours 125°C burn-in