

# 3.75-6.5 Watt Hybrid

## Features

- Rad Hard: TID > 100kRad(Si)
- 2:1 margin: Operates beyond 200kRad TID
- No SEE: LET > 82MeV\*cm<sup>2</sup>/mg
- Proton Resistant: No optocouplers used
- Specifically engineered for 50 VDC satellite bus
- Completely self contained Thick Film Hybrid DC-DC Converter
- No external filter caps required
- Fully isolated design
- "Inhibit-not" function
- Power on soft start
- 200 kHz operation for low ripple and fast response time
- Built-in EMI input filter meets MIL-STD-461C requirements CE01, CE03, CS01, CS02 and CS06
- Short circuit and overvoltage protection
- Capability of external sync for switching frequencies
- Built-in test capability

## Specifications

**INPUT:** 50 VDC nominal

Range: 30 to 75 VDC continuous

### ISOLATION:

Input to case: 500 VDC

Input to output: 500 VDC

Output to case: 100 VDC

### ENVIRONMENT:

Storage temperature: -55°C to +150°C

Shock: 50 G's

Acceleration: 500 G's

Vibration: 30 G's

Grades EU, L, R & S:

Full Power Output at T<sub>case</sub> = +85°C

Linearly derates to zero at T<sub>case</sub> = +115°C

Grades LE, RE & SE:

Full Power Output at T<sub>case</sub> = +125°C

Linearly derates to zero at T<sub>case</sub> = +135°C

Grades L & LE:

TID up to 45kRad(Si)

No SEE up to 60MeV\*cm<sup>2</sup>/mg

**WEIGHT:** 50 grams typical

SINGLE OUTPUT DEVICES		7690-S03.3 (6.5W)			7690-S05 (6.5W)			7690-S05.2 (6.5W)			7690-S12 (6.5W)		
PARAMETER	CONDITION	MIN	TYP	MAX	MIN	TYP	MAX	MIN	TYP	MAX	MIN	TYP	MAX
Output voltage	—	+3.2	+3.3	+3.4	+4.9	+5.0	+5.1	+5.1	+5.2	+5.3	+11.9	+12.0	+12.1
Output current	V <sub>in min</sub> — V <sub>in max</sub>	—	—	1.97A	—	—	1.3A	—	—	1.25A	—	—	541mA
Efficiency	P <sub>out</sub> = max rated load	65%	68%	—	70%	73%	—	70%	73%	—	77%	81%	—
Line regulation	P <sub>out</sub> = max rated load V <sub>in min</sub> — V <sub>in max</sub>	—	10mV	30mV	—	10mV	50mV	—	10mV	50mV	—	20mV	100mV
Load regulation	P <sub>out</sub> = 10% to F.L.	—	10mV	30mV	—	10mV	50mV	—	10mV	50mV	—	20mV	100mV
Output ripple	F.L. BW 2 MHz mV <sub>pp</sub>	—	30	65	—	40	85	—	40	85	—	60	150

SINGLE OUTPUT DEVICES		7690-S15 (6.5W)			7690-S28 (6.5W)								
PARAMETER	CONDITION	MIN	TYP	MAX	MIN	TYP	MAX						
Output voltage	—	+14.9	+15.0	+15.1	+27.8	+28.0	+28.2						
Output current	V <sub>in min</sub> — V <sub>in max</sub>	—	—	433mA	—	—	232mA						
Efficiency	P <sub>out</sub> = max rated load	78%	82%	—	77%	81%	—						
Line regulation	P <sub>out</sub> = max rated load V <sub>in min</sub> — V <sub>in max</sub>	—	25mV	125mV	—	50mV	250mV						
Load regulation	P <sub>out</sub> = 10% to F.L.	—	25mV	125mV	—	50mV	250mV						
Output ripple	F.L. BW 2 MHz mV <sub>pp</sub>	—	75	180	—	150	350						

Model No.	Case Style	Pin Count	Mounting
7690	2	12	Solder Sealed Flangeless PCB Mount
7690	F	12	Solder Sealed PCB Mount with Flange
7690	G	12	Seam Weld Flangeless PCB Mount
7690	GF	12	Seam Weld PCB Mount with Flange
7690	UF	12	Seam Weld Chassis Mount with Flange

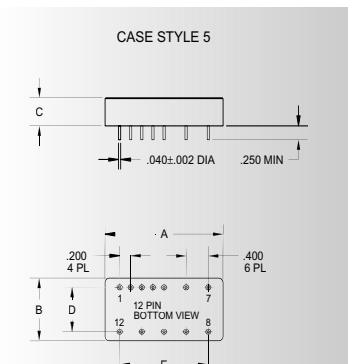
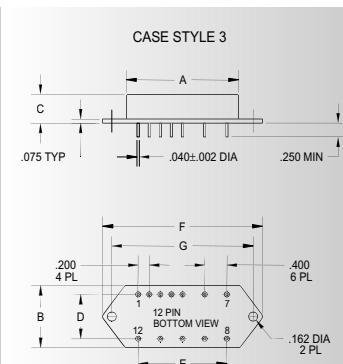
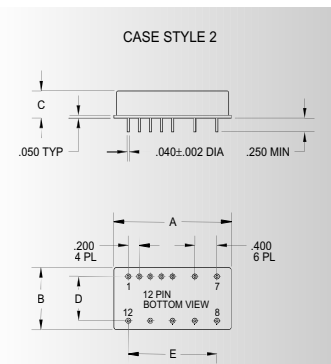

TOLERANCES: ALL DIMENSIONS ±0.01 EXCEPT F = MAX, C = +0.01/-0.02; DRAWINGS IN INCHES.

## Case Dimensions

Units: inches | millimeters

Case Style	A	B	C	D	E	F	G
2	2.130   54.102	1.120   28.448	0.375   9.525	0.800   20.320	1.600   40.640	—   —	—   —
3 F	2.130   54.102	1.120   28.448	0.375   9.525	0.800   20.320	1.600   40.640	2.890   73.406	2.550   64.770
5 G	2.130   54.102	1.120   28.448	0.375   9.525	0.800   20.320	1.600   40.640	—   —	—   —
6 GF	2.130   54.102	1.120   28.448	0.375   9.525	0.800   20.320	1.600   40.640	2.890   73.406	2.550   64.770
8 UF	2.160   54.864	1.510   38.354	0.495   12.573	—   —	1.600   40.640	2.890   73.406	2.550   64.770

# DC-DC CONVERTERS

## PROTON RAD HARD 100K+™ SERIES

# 7690

**MAGNETICALLY ISOLATED**



**50 VDC**

DUAL OUTPUT DEVICES		7690-D05 (6.5W)			7690-D12 (6.5W)			7690-D15 (6.5W)		
PARAMETER	CONDITION	MIN	TYP	MAX	MIN	TYP	MAX	MIN	TYP	MAX
Output voltage	$+I_{out} = -I_{out}$	+4.9	+5.0	+5.1	+11.9	+12.0	+12.1	+14.9	+15.0	+15.1
		-4.9	-5.0	-5.1	-11.9	-12.0	-12.1	-14.9	-15.0	-15.1
Output current*	$V_{in min} - V_{in max}$	±35mA	—	±625mA	±35mA	—	±270mA	±32mA	—	±217mA
Efficiency	$P_{out} = \text{max rated load}$	72%	75%	—	77%	81%	—	78%	82%	—
Line regulation	$P_{out} = \text{max rated load}$ $V_{in min} - V_{in max}$	—	±10mV	±50mV	—	±20mV	±100mV	—	±25mV	±125mV
Load regulation†	$P_{out} = 10\%$ to F.L.	—	±10mV	±50mV	—	±20mV	±100mV	—	±25mV	±125mV
Output ripple	F.L. BW 2 MHz mV <sub>pp</sub>	—	40	85	—	60	150	—	75	180

Notes: \*Up to 90% full power available from either output if rated output power is not exceeded; †balanced load conditions.

TRIPLE OUTPUT DEVICES		7690-T3.3/5 (3.75W)			7690-T3.3/12 (5W)			7690-T3.3/15 (5W)			7690-T05 (3.75W)			7690-T12 (5W)			7690-T15 (5W)					
PARAMETER	CONDITION	MIN	TYP	MAX	MIN	TYP	MAX	MIN	TYP	MAX	MIN	TYP	MAX	MIN	TYP	MAX	MIN	TYP	MAX			
Output voltage	$+I_{out} = -I_{out}$	+3.2	+3.3	+3.4	+3.2	+3.3	+3.4	+3.2	+3.3	+3.4	+4.9	+5.0	+5.1	+4.9	+5.0	+5.1	+11.9	+12.0	+12.1	+14.9	+15.0	+15.1
		-4.9	-5.0	-5.1	-11.9	-12.0	-12.1	-14.9	-15.0	-15.1	-4.9	-5.0	-5.1	-11.9	-12.0	-12.1	-14.9	-15.0	-15.1	-14.9	-15.0	-15.1
Output current	$V_{in min} - V_{in max}$	75mA	—	750mA	75mA	—	750mA	75mA	—	750mA	50mA	—	500mA	50mA	—	500mA	50mA	—	500mA	50mA	—	500mA
		±20mA	—	±150mA	±20mA	—	±105mA	±20mA	—	±83mA	±20mA	—	±150mA	±20mA	—	±105mA	±20mA	—	±105mA	±20mA	—	±83mA
Efficiency	$P_{out} = \text{max rated load}$	65%	68%	—	65%	68%	—	65%	68%	—	65%	68%	—	69%	73%	—	70%	73%	—	—	—	—
Line regulation	$P_{out} = \text{max rated load}$ $V_{in min} - V_{in max}$	—	10mV	50mV	—	10mV	50mV	—	10mV	50mV	—	10mV	50mV	—	10mV	50mV	—	10mV	50mV	—	10mV	50mV
		—	25mV	50mV	—	25mV	50mV	—	25mV	50mV	—	25mV	50mV	—	25mV	50mV	—	25mV	50mV	—	25mV	50mV
Load regulation	$P_{out} = 10\%$ to F.L.	—	10mV	50mV	—	10mV	50mV	—	10mV	50mV	—	10mV	50mV	—	10mV	50mV	—	10mV	50mV	—	10mV	50mV
		—	25mV	50mV	—	25mV	50mV	—	25mV	50mV	—	25mV	50mV	—	25mV	50mV	—	25mV	50mV	—	25mV	50mV
Output ripple	F.L. BW 2 MHz mV <sub>pp</sub>	—	30	65	—	30	65	—	30	65	—	40	85	—	40	85	—	40	85	—	40	85
		—	—	50	—	—	50	—	—	50	—	—	50	—	—	50	—	—	50	—	—	50

CASE STYLE 6

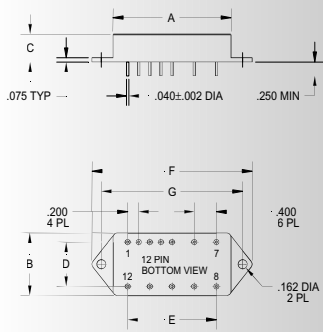

CASE STYLE 8

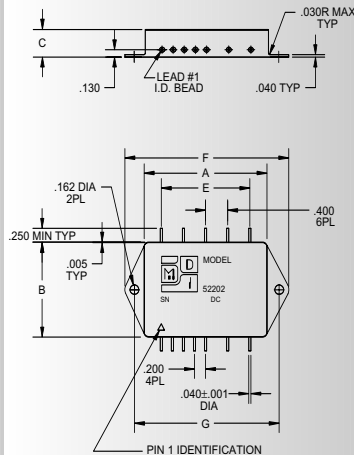

**7690-SXX output <24 VDC**

Pin 1	bit	Pin 7	+ input
Pin 2	inhibit not	Pin 8	main output
Pin 3	soft start	Pin 9	main output ret
Pin 4	sync	Pin 10	N/C
Pin 5	N/C	Pin 11	adjust
Pin 6	input ret	Pin 12	N/C

**7690-SXX output ≥24 VDC**

Pin 1	bit	Pin 7	+ input
Pin 2	inhibit not	Pin 8	N/C
Pin 3	soft start	Pin 9	N/C
Pin 4	sync	Pin 10	main output
Pin 5	N/C	Pin 11	N/C
Pin 6	input ret	Pin 12	main output ret

**7690-DXX**

Pin 1	bit	Pin 7	+ input
Pin 2	inhibit not	Pin 8	N/C
Pin 3	soft start	Pin 9	N/C
Pin 4	sync	Pin 10	+ dual output
Pin 5	N/C	Pin 11	dual output ret
Pin 6	input ret	Pin 12	- dual output

**7690-TXX**

Pin 1	bit	Pin 7	+ input
Pin 2	inhibit not	Pin 8	main output
Pin 3	soft start	Pin 9	main output ret
Pin 4	sync	Pin 10	+ dual output
Pin 5	N/C	Pin 11	dual output ret
Pin 6	input ret	Pin 12	- dual output

Please specify **GRADE LEVEL** for your application. EU grade units will be shipped if no option is specified.

**EU** Engineering Units  
**R** 100 K+™, +85°C military/aerospace  
**L** 45 K, +85°C military/aerospace

**RE** 100 K+™, +125°C military/aerospace  
**S** 100 K+™, +85°C space  
**LE** 45 K, +125°C military/aerospace

**SE** 100 K+™, +125°C space