

12.5-30 Watt Hybrid

Features

- Rad Hard: TID > 100kRad(Si)
- 2:1 margin: Operates beyond 200kRad TID
- No SEE: LET > 82MeV*cm²/mg
- Proton Resistant: No optocouplers used
- Specifically designed for 100 VDC satellite bus
- Completely self contained Thick Film Hybrid DC-DC Converter
- No external filter caps required
- Fully isolated design
- "Inhibit-not" function
- Power on soft start
- 200 kHz operation for low ripple and fast response time
- Built-in EMI input filter meets MIL-STD-461C requirements CE01, CE03, CS01, CS02 and CS06
- Short circuit and overvoltage protection
- Capability of external sync for switching frequencies
- Built-in test capability

Specifications

INPUT: 100 VDC nominal

Range: 80 to 120 VDC continuous

ISOLATION:

Input to case: 500 VDC

Input to output: 500 VDC

Output to case: 100 VDC

ENVIRONMENT:

Storage temperature: -55°C to +150°C

Shock: 50 G's

Acceleration: 500 G's

Vibration: 30 G's

Grades EU, L, R & S:

Full Power Output at T_{case} = +85°C

Linearly derates to zero at T_{case} = +115°C

Grades LE, RE & SE:

Full Power Output at T_{case} = +125°C

Linearly derates to zero at T_{case} = +135°C

Grades L & LE:

TID up to 45kRad(Si)

No SEE up to 60MeV*cm²/mg

WEIGHT: 75 grams typical

SINGLE OUTPUT DEVICES		9680-S02 (12W)			9680-S02.5 (15W)			9680-S03.3 (20W)			9680-S05 (30W)		
PARAMETER	CONDITION	MIN	TYP	MAX	MIN	TYP	MAX	MIN	TYP	MAX	MIN	TYP	MAX
Output voltage	—	+1.9	+2.0	+2.1	+2.4	+2.5	+2.6	+3.2	+3.3	+3.4	+4.9	+5.0	+5.1
Output current	V _{in min} — V _{in max}	—	—	6.06A	—	—	6.06A	—	—	6.06A	—	—	6A
Efficiency	P _{out} = max rated load	56%	59%	—	61%	64%	—	66%	69%	—	71%	74%	—
Line regulation	P _{out} = max rated load V _{in min} — V _{in max}	—	10mV	30mV	—	10mV	30mV	—	10mV	30mV	—	10mV	50mV
Load regulation	P _{out} = 10% to F.L.	—	10mV	30mV	—	10mV	30mV	—	10mV	30mV	—	10mV	50mV
Output ripple	F.L. BW 2 MHz mV _{pp}	—	25	50	—	30	60	—	30	65	—	40	85

SINGLE OUTPUT DEVICES		9680-S05.2 (30W)			9680-S12 (30W)			9680-S15 (30W)			9680-S28 (30W)		
PARAMETER	CONDITION	MIN	TYP	MAX	MIN	TYP	MAX	MIN	TYP	MAX	MIN	TYP	MAX
Output voltage	—	+5.1	+5.2	+5.3	+11.9	+12.0	+12.1	+14.9	+15.0	+15.1	+27.8	+28.0	+28.2
Output current	V _{in min} — V _{in max}	—	—	5.76A	—	—	2.5A	—	—	2A	—	—	1.07A
Efficiency	P _{out} = max rated load	71%	74%	—	78%	82%	—	79%	83%	—	78%	82%	—
Line regulation	P _{out} = max rated load V _{in min} — V _{in max}	—	10mV	50mV	—	20mV	100mV	—	25mV	125mV	—	50mV	250mV
Load regulation	P _{out} = 10% to F.L.	—	10mV	50mV	—	20mV	100mV	—	25mV	125mV	—	50mV	250mV
Output ripple	F.L. BW 2 MHz mV _{pp}	—	40	85	—	60	150	—	75	180	—	150	350

Model No.	Case Style	Pin Count	Mounting
9680	2	12	Solder Sealed Flangeless PCB Mount
9680	F *	3 *	Solder Sealed PCB Mount with Flange
9680	I	5	Seam Weld Flangeless PCB Mount
9680	IF *	6 *	Seam Weld PCB Mount with Flange
9680	WF	8	Seam Weld Chassis Mount with Flange
9680	PB	10	Solder Sealed Flangeless PCB Stud Mount
9680	PE	12	Seam Weld Flangeless PCB Stud Mount

* Inverted Mounting Bracket Available

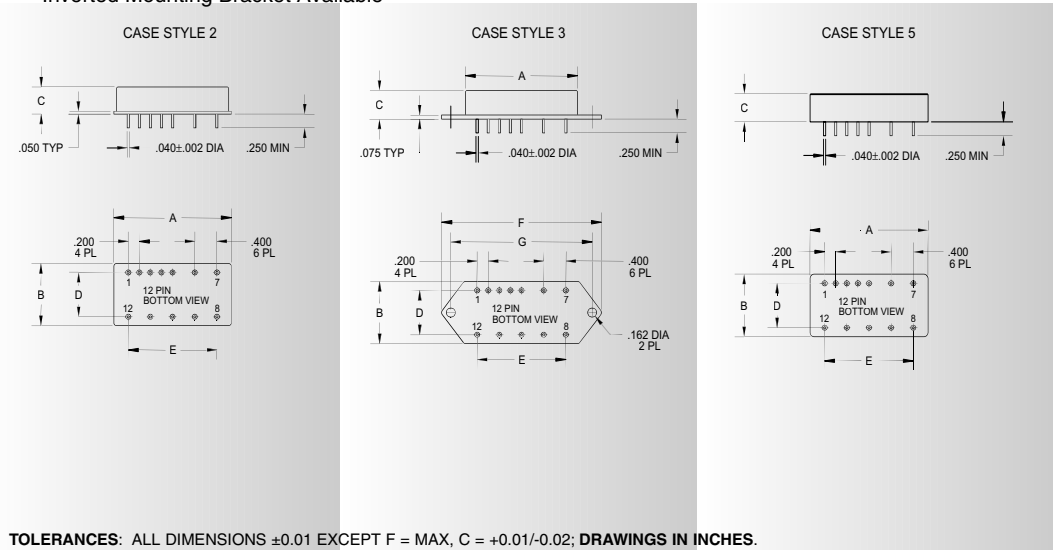

TOLERANCES: ALL DIMENSIONS ±0.01 EXCEPT F = MAX, C = +0.01/-0.02; DRAWINGS IN INCHES.

Case Dimensions

Units: inches | millimeters

Case Style	A	B	C	D	E	F	G
2	2.200 55.880	1.350 34.290	0.495 12.573	1.000 25.400	1.600 40.640	— —	— —
3 F	2.200 55.880	1.350 34.290	0.495 12.573	1.000 25.400	1.600 40.640	2.960 75.184	2.610 66.294
5 I	2.225 56.515	1.350 34.290	0.495 12.573	1.000 25.400	1.600 40.640	— —	— —
6 IF	2.225 56.515	1.350 34.290	0.495 12.573	1.000 25.400	1.600 40.640	2.960 75.184	2.610 66.294
8 WF	2.225 56.515	1.710 43.434	0.495 12.573	— —	1.600 40.640	2.960 75.184	2.610 66.294
10 PB	2.225 56.515	1.350 34.290	0.495 12.573	1.000 25.400	1.600 40.640	— —	— —
12 PE	2.225 56.515	1.350 34.290	0.495 12.573	1.000 25.400	1.600 40.640	— —	— —

DC-DC CONVERTERS

PROTON RAD HARD 100K+™ SERIES

9680

MAGNETICALLY ISOLATED



100 VDC

0006

DUAL OUTPUT DEVICES		9680-D05 (30W)			9680-D12 (30W)			9680-D15 (30W)		
PARAMETER	CONDITION	MIN	TYP	MAX	MIN	TYP	MAX	MIN	TYP	MAX
Output voltage	$+I_{out} = -I_{out}$	+4.9	+5.0	+5.1	+11.9	+12.0	+12.1	+14.9	+15.0	+15.1
		-4.9	-5.0	-5.1	-11.9	-12.0	-12.1	-14.9	-15.0	-15.1
Output current*	$V_{in\ min} - V_{in\ max}$	±150mA	—	±3A	±95mA	—	±1.25A	±76mA	—	±1A
Efficiency	$P_{out} = \text{max rated load}$	72%	76%	—	78%	82%	—	79%	83%	—
Line regulation	$P_{out} = \text{max rated load}$ $V_{in\ min} - V_{in\ max}$	—	±10mV	±50mV	—	±20mV	±100mV	—	±25mV	±125mV
Load regulation†	$P_{out} = 10\%$ to F.L.	—	±10mV	±50mV	—	±20mV	±100mV	—	±25mV	±125mV
Output ripple	F.L. BW 2 MHz mV _{pp}	—	40	85	—	60	150	—	75	180

Notes: *Up to 90% full power available from either output if rated output power is not exceeded; †balanced load conditions.

TRIPLE OUTPUT DEVICES		9680-T3.3/5 (12.5W)			9680-T3.3/12 (17.5W)			9680-T3.3/15 (17.5W)			9680-T05 (12.5W)			9680-T12 (17.5W)			9680-T15 (17.5W)		
PARAMETER	CONDITION	MIN	TYP	MAX	MIN	TYP	MAX	MIN	TYP	MAX	MIN	TYP	MAX	MIN	TYP	MAX	MIN	TYP	MAX
Output voltage	$+I_{out} = -I_{out}$	+3.2	+3.3	+3.4	+3.2	+3.3	+3.4	+3.2	+3.3	+3.4	+4.9	+5.0	+5.1	+4.9	+5.0	+5.1	+4.9	+5.0	+5.1
		-4.9	-5.0	-5.1	-11.9	-12.0	-12.1	-14.9	-15.0	-15.1	-4.9	-5.0	-5.1	-11.9	-12.0	-12.1	-14.9	-15.0	-15.1
Output current	$V_{in\ min} - V_{in\ max}$	300mA	—	3A	300mA	—	3A	300mA	—	3A	200mA	—	2A	200mA	—	2A	200mA	—	2A
		±40mA	—	±250mA	±40mA	—	±312mA	±32mA	—	±250mA	±40mA	—	±250mA	±40mA	—	±312mA	±32mA	—	±250mA
Efficiency	$P_{out} = \text{max rated load}$	66%	69%	—	66%	69%	—	66%	69%	—	66%	69%	—	71%	74%	—	71%	74%	—
Line regulation	$P_{out} = \text{max rated load}$ $V_{in\ min} - V_{in\ max}$	—	10mV	50mV	—	10mV	50mV	—	10mV	50mV	—	10mV	50mV	—	10mV	50mV	—	10mV	50mV
		—	25mV	50mV	—	25mV	50mV	—	25mV	50mV	—	25mV	50mV	—	25mV	50mV	—	25mV	50mV
Load regulation	$P_{out} = 10\%$ to F.L.	—	10mV	50mV	—	10mV	50mV	—	10mV	50mV	—	10mV	50mV	—	10mV	50mV	—	10mV	50mV
		—	25mV	50mV	—	25mV	50mV	—	25mV	50mV	—	25mV	50mV	—	25mV	50mV	—	25mV	50mV
Output ripple	F.L. BW 2 MHz mV _{pp}	—	30	65	—	30	65	—	30	65	—	40	85	—	40	85	—	40	85
		—	—	50	—	—	50	—	—	50	—	—	50	—	—	50	—	—	50

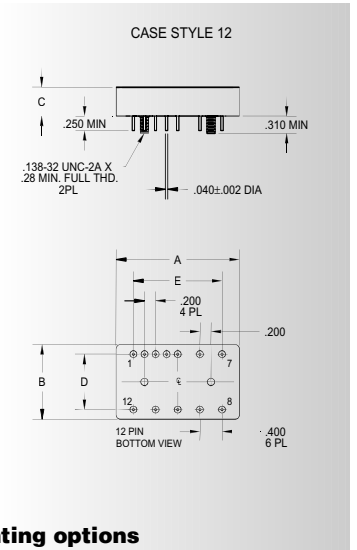
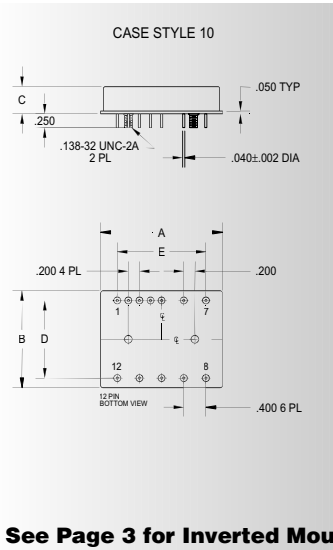
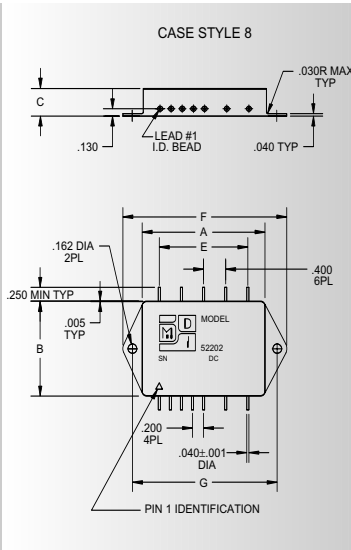
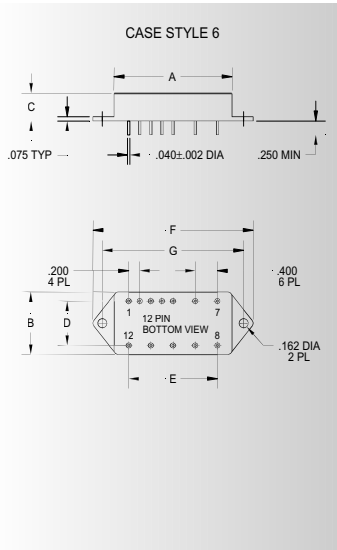

See Page 3 for Inverted Mounting options

9680-SXX output <24 VDC			9680-SXX output ≥24 VDC			9680-DXX			9680-TXX		
Pin	Function	Pin	Pin	Function	Pin	Pin	Function	Pin	Pin	Function	
Pin 1	bit	Pin 7	Pin 1	bit	Pin 7	Pin 1	bit	Pin 7	Pin 1	bit	
Pin 2	inhibit not	Pin 8	Pin 2	inhibit not	Pin 8	Pin 2	inhibit not	Pin 8	Pin 2	inhibit not	
Pin 3	soft start	Pin 9	Pin 3	soft start	Pin 9	Pin 3	soft start	Pin 9	Pin 3	soft start	
Pin 4	sync	Pin 10	Pin 4	sync	Pin 10	Pin 4	sync	Pin 10	Pin 4	sync	
Pin 5	N/C	Pin 11	Pin 5	adjust	Pin 11	Pin 5	adjust	Pin 11	Pin 5	N/C	
Pin 6	input ret	Pin 12	Pin 6	input ret	Pin 12	Pin 6	input ret	Pin 12	Pin 6	input ret	

Please specify **GRADE LEVEL** for your application. EU grade units will be shipped if no option is specified.

EU Engineering Units
R 100 K+™, +85°C military/aerospace
L 45 K, +85°C military/aerospace

RE 100 K+™, +125°C military/aerospace
S 100 K+™, +85°C space
LE 45 K, +125°C military/aerospace

SE 100 K+™, +125°C space

Inverted Mounting Bracket Dimensions for 9680 F(3) or IF(6)

Brackets are constructed of rugged aluminum alloy with self-locking 6-32 inserts for high thermal conductivity to the system heatsink and vibration/shock resistance. A high conductivity thermal pad (Fujipoly Sarcon™ GSR) is included with each kit as is all mounting hardware except the four fasteners for system chassis panel attachment.

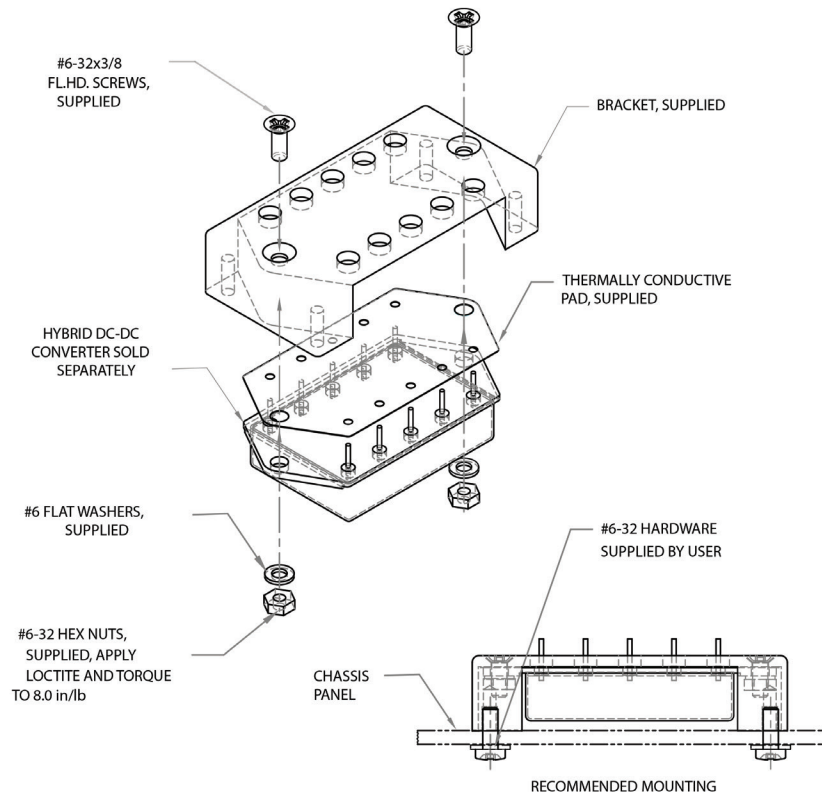

Typical Inverted Mounting Assembly Drawing

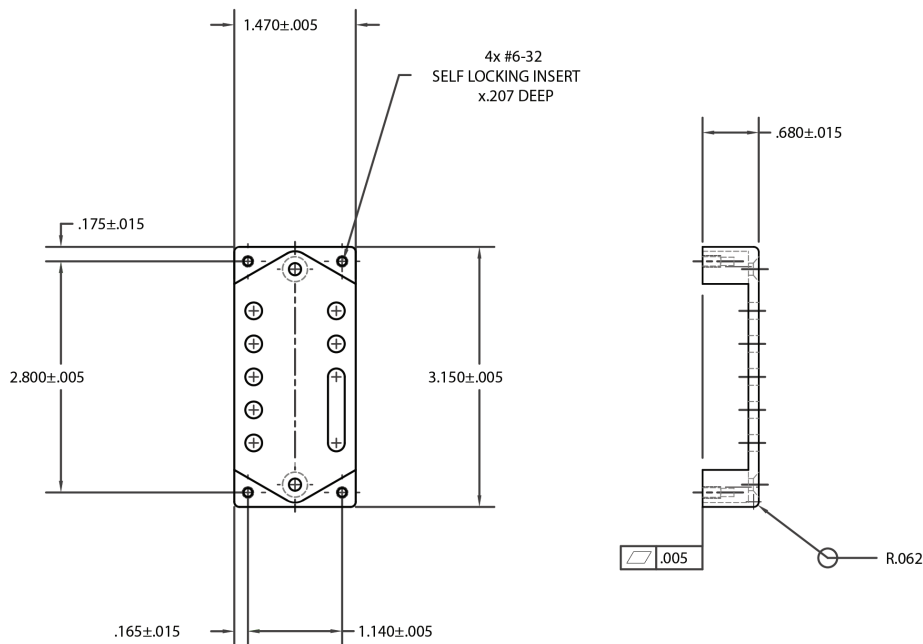

Inverted Mounting Kit P/N: 403-007 Thermal Pad P/N: 301-92
T Rise 1.94°C per Watt Dissipated