

7.5-20 Watt Hybrid

Features

- Rad Hard: TID > 100kRad(Si)
- 2:1 margin: Operates beyond 200kRad TID
- No SEE: LET > 82MeV*cm²/mg
- Proton Resistant: No optocouplers used
- Specifically designed for redundant or individual space applications
- Completely self contained Thick Film Hybrid DC-DC Converter
- No external filter caps required
- Fully isolated design
- "Inhibit-not" function
- Power on soft start
- 200 kHz operation for low ripple and fast response time
- Built-in EMI input filter meets MIL-STD-461C requirements CE01, CE03, CS01, CS02 and CS06
- Short circuit and overvoltage protection
- Capability of external sync for switching frequencies
- Built-in test capability

Specifications

INPUT: 28 VDC nominal
 Range: 16 to 50 VDC continuous
 18 to 50 VDC full power
 Survives 80 V transients/MIL-STD-704A

ISOLATION:

Input to case: 500 VDC
 Input to output: 500 VDC
 Output to case: 100 VDC

ENVIRONMENT:

Storage temperature: -55°C to +150°C
 Shock: 50 G's
 Acceleration: 500 G's
 Vibration: 30 G's

Grades EU, L & S:

Full Power Output at T_{case} = +85°C
 Linearly derates to zero at T_{case} = +115°C

Grades LE LE & SE:

Full Power Output at T_{case} = +125°C
 Linearly derates to zero at T_{case} = +135°C

Grades L & LE:

TID up to 45kRad(Si)
 No SEE up to 60MeV*cm²/mg

WEIGHT: 60 grams typical

SINGLE OUTPUT DEVICES		5107-S02 (8W)			5107-S02.5 (10W)			5107-S03.3 (13.2W)			5107-S05 (20W)		
PARAMETER	CONDITION	MIN	TYP	MAX	MIN	TYP	MAX	MIN	TYP	MAX	MIN	TYP	MAX
Output voltage	—	+1.9	+2.0	+2.1	+2.4	+2.5	+2.6	+3.2	+3.3	+3.4	+4.9	+5.0	+5.1
Output current	V _{in min} — V _{in max}	—	—	4A	—	—	4A	—	—	4A	—	—	4A
Efficiency	P _{out} = max rated load	55%	58%	—	60%	63%	—	65%	68%	—	70%	73%	—
Line regulation	P _{out} = max rated load V _{in min} — V _{in max}	—	10mV	30mV	—	10mV	30mV	—	10mV	30mV	—	10mV	50mV
Load regulation	P _{out} = 10% to F.L.	—	10mV	30mV	—	10mV	30mV	—	10mV	30mV	—	10mV	50mV
Output ripple	F.L. BW 2 MHz mV _{pp}	—	25	50	—	30	60	—	30	65	—	40	85

SINGLE OUTPUT DEVICES		5107-S05.2 (20W)			5107-S12 (20W)			5107-S15 (20W)			5107-S28 (20W)		
PARAMETER	CONDITION	MIN	TYP	MAX	MIN	TYP	MAX	MIN	TYP	MAX	MIN	TYP	MAX
Output voltage	—	+5.1	+5.2	+5.3	+11.9	+12.0	+12.1	+14.9	+15.0	+15.1	+27.8	+28.0	+28.2
Output current	V _{in min} — V _{in max}	—	—	3.85A	—	—	1.67A	—	—	1.33A	—	—	714mA
Efficiency	P _{out} = max rated load	70%	73%	—	76%	80%	—	77%	81%	—	76%	80%	—
Line regulation	P _{out} = max rated load V _{in min} — V _{in max}	—	10mV	50mV	—	20mV	100mV	—	25mV	125mV	—	50mV	250mV
Load regulation	P _{out} = 10% to F.L.	—	10mV	50mV	—	20mV	100mV	—	25mV	125mV	—	50mV	250mV
Output ripple	F.L. BW 2 MHz mV _{pp}	—	40	85	—	60	150	—	75	180	—	150	350

Model No.	Case Style	Pin Count	Mounting
5107	2	12	Solder Sealed Flangeless PCB Mount
5107	F	12	Solder Sealed PCB Mount with Flange
5107	H	12	Seam Weld Flangeless PCB Mount
5107	HF	12	Seam Weld PCB Mount with Flange
5107	VF	12	Seam Weld Chassis Mount with Flange

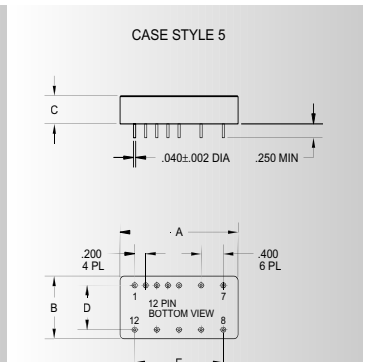
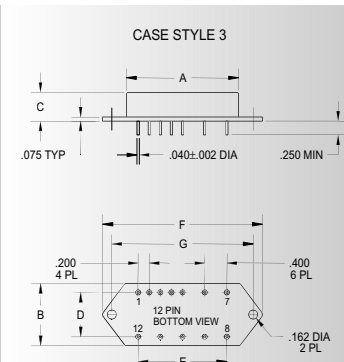
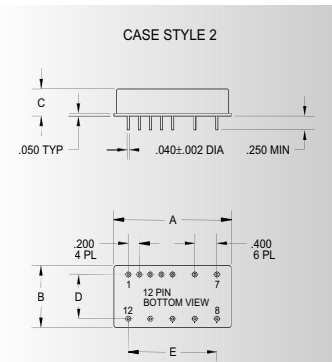

TOLERANCES: ALL DIMENSIONS ±0.01 EXCEPT F = MAX, C = +0.01/-0.02; DRAWINGS IN INCHES.

Case Dimensions

Units: inches | millimeters

Case Style	A	B	C	D	E	F	G
2	2.130 54.102	1.120 28.448	0.495 12.573	0.800 20.320	1.600 40.640	— —	— —
3 F	2.130 54.102	1.120 28.448	0.495 12.573	0.800 20.320	1.600 40.640	2.890 73.406	2.550 64.770
5 H	2.130 54.102	1.120 28.448	0.495 12.573	0.800 20.320	1.600 40.640	— —	— —
6 HF	2.130 54.102	1.120 28.448	0.495 12.573	0.800 20.320	1.600 40.640	2.890 73.406	2.550 64.770
8 VF	2.160 54.864	1.510 38.354	0.495 12.573	— —	1.600 40.640	2.890 73.406	2.550 64.770

DC-DC CONVERTERS

PROTON RAD HARD 100K+™ SERIES

5107

MAGNETICALLY ISOLATED



28 VDC

DUAL OUTPUT DEVICES		5107-D3.3/5 (11.6W)			5107-D05 (20W)			5107-D12 (20W)			5107-D15 (20W)		
PARAMETER	CONDITION	MIN	TYP	MAX	MIN	TYP	MAX	MIN	TYP	MAX	MIN	TYP	MAX
Output voltage	$+I_{out} = -I_{out}$	+3.2	+3.3	+3.4	+4.9	+5.0	+5.1	+11.9	+12.0	+12.1	+14.9	+15.0	+15.1
		+4.9	+5.0	+5.1	-4.9	-5.0	-5.1	-11.9	-12.0	-12.1	-14.9	-15.0	-15.1
Output current*	$V_{in\ min} - V_{in\ max}$	200mA	—	2A	±150mA	—	±2A	±125mA	—	±833mA	±100mA	—	±667mA
		100mA	—	1A	—	—	—	—	—	—	—	—	—
Efficiency	$P_{out} = \text{max rated load}$	62%	65%	—	70%	74%	—	76%	80%	—	77%	81%	—
Line regulation	$P_{out} = \text{max rated load}$ $V_{in\ min} - V_{in\ max}$	—	10mV	30mV	—	±10mV	±50mV	—	±20mV	±100mV	—	±25mV	±125mV
		—	10mV	50mV	—	±10mV	±50mV	—	±20mV	±100mV	—	±25mV	±125mV
Load regulation†	$P_{out} = 10\%$ to F.L.	—	10mV	30mV	—	±10mV	±50mV	—	±20mV	±100mV	—	±25mV	±125mV
		—	10mV	50mV	—	±10mV	±50mV	—	±20mV	±100mV	—	±25mV	±125mV
Output ripple	F.L. BW 2 MHz mV _{pp}	—	30	65	—	40	85	—	60	150	—	75	180
		—	25	50	—	—	—	—	—	—	—	—	—

Notes: *Up to 90% full power available from either output if rated output power is not exceeded; †balanced load conditions.

TRIPLE OUTPUT DEVICES		5107-T3.3/5 (7.5W)			5107-T3.3/12 (10W)			5107-T3.3/15 (10W)			5107-T05 (7.5W)			5107-T12 (10W)			5107-T15 (10W)					
PARAMETER	CONDITION	MIN	TYP	MAX	MIN	TYP	MAX	MIN	TYP	MAX	MIN	TYP	MAX	MIN	TYP	MAX	MIN	TYP	MAX			
Output voltage	$+I_{out} = -I_{out}$	+3.2	+3.3	+3.4	+3.2	+3.3	+3.4	+3.2	+3.3	+3.4	+4.9	+5.0	+5.1	+4.9	+5.0	+5.1	+11.9	+12.0	+12.1	+14.9	+15.0	+15.1
		+4.9	+5.0	+5.1	+11.9	+12.0	+12.1	+14.9	+15.0	+15.1	-4.9	-5.0	-5.1	-11.9	-12.0	-12.1	-14.9	-15.0	-15.1			
Output current	$V_{in\ min} - V_{in\ max}$	150mA	—	1.5A	150mA	—	1.5A	150mA	—	1.5A	100mA	—	1A	100mA	—	1A	100mA	—	1A	100mA	—	1A
		±15mA	—	±250mA	±15mA	—	±208mA	±15mA	—	±167mA	±15mA	—	±250mA	±15mA	—	±208mA	±15mA	—	±167mA			
Efficiency	$P_{out} = \text{max rated load}$	65%	68%	—	65%	68%	—	65%	68%	—	64%	67%	—	69%	72%	—	69%	72%	—	69%	72%	—
Line regulation	$P_{out} = \text{max rated load}$ $V_{in\ min} - V_{in\ max}$	—	10mV	50mV	—	10mV	50mV	—	10mV	50mV	—	10mV	50mV	—	10mV	50mV	—	10mV	50mV	—	10mV	50mV
		—	25mV	50mV	—	25mV	50mV	—	25mV	50mV	—	25mV	50mV	—	25mV	50mV	—	25mV	50mV	—	25mV	50mV
Load regulation	$P_{out} = 10\%$ to F.L.	—	10mV	50mV	—	10mV	50mV	—	10mV	50mV	—	10mV	50mV	—	10mV	50mV	—	10mV	50mV	—	10mV	50mV
		—	25mV	50mV	—	25mV	50mV	—	25mV	50mV	—	25mV	50mV	—	25mV	50mV	—	25mV	50mV	—	25mV	50mV
Output ripple	F.L. BW 2 MHz mV _{pp}	—	30	65	—	30	65	—	30	65	—	40	85	—	40	85	—	40	85	—	40	85
		—	—	50	—	—	50	—	—	50	—	—	50	—	—	50	—	—	50	—	—	50

CASE STYLE 6

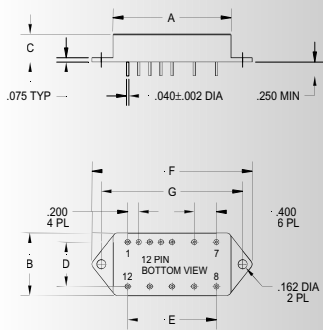

CASE STYLE 8

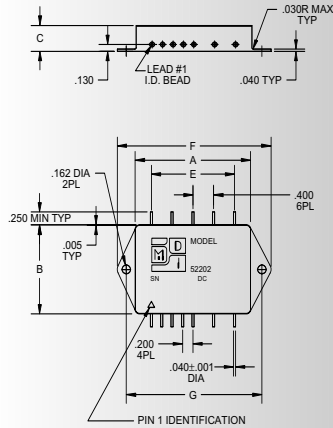

5107-SXX output <24 VDC

Pin 1	bit	Pin 7	+ input
Pin 2	inhibit not	Pin 8	main output
Pin 3	soft start	Pin 9	main output ret
Pin 4	sync	Pin 10	N/C
Pin 5	N/C	Pin 11	adjust
Pin 6	input ret	Pin 12	N/C

5107-SXX output ≥24 VDC

Pin 1	bit	Pin 7	+ input
Pin 2	inhibit not	Pin 8	N/C
Pin 3	soft start	Pin 9	N/C
Pin 4	sync	Pin 10	main output
Pin 5	N/C	Pin 11	N/C
Pin 6	input ret	Pin 12	main output ret

5107-DXX

Pin 1	bit	Pin 7	+ input
Pin 2	inhibit not	Pin 8	N/C
Pin 3	soft start	Pin 9	N/C
Pin 4	sync	Pin 10	+ dual output
Pin 5	N/C	Pin 11	dual output ret
Pin 6	input ret	Pin 12	- dual output

5107-TXX

Pin 1	bit	Pin 7	+ input
Pin 2	inhibit not	Pin 8	main output
Pin 3	soft start	Pin 9	main output ret
Pin 4	sync	Pin 10	+ dual output
Pin 5	N/C	Pin 11	dual output ret
Pin 6	input ret	Pin 12	- dual output

Please specify **GRADE LEVEL** for your application. EU grade units will be shipped if no option is specified.

EU Engineering Units
L 45 K+™, +85°C military/aerospace

LE 45 K+™, +125°C military/aerospace **S**
100 K+™, +85°C space

SE 100 K+™, +125°C space